



Model

NS250HD

Product Description

Slicer, 10", Heavy Duty

Product Code

5S251N

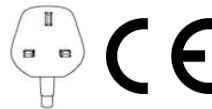

Standard Features

- Designed for handling larger volumes than medium duty range. Recommended for delis, restaurants, supermarkets and canteens
- Hollow ground chromed carbon steel blade
- Powerful twin 'V' belt driven transmission gives a smooth cutting action and silent running
- Easy belt adjustment
- Easy set thickness control allows for precision slicing
- Carriage slides on ball bearings for smooth carriage glide
- Made from high polished, anodised food grade aluminium for durability and hygiene
- Large base to ensure slicer has a large capacity to cope with large products
- Ergonomic design with smooth rounded edges to allow for fast and easy cleaning and improved levels of hygiene
- Fully interlocked and safe guarded for full compliance of CE legislation. This ensures all-round blade protection for ultimate user safety during cleaning
- Built-in, self-aligning sharpening and de-burring unit
- Table / carriage, blade cover, blade and sharpening unit are detachable for easy cleaning
- Transparent slicing guard to ensure ultimate user safety whilst slicing
- Optional voltages and frequencies available on request
- CE Approved

Standard Accessories

- 1 x Knife Remover
- 1 x Tasteless Oil
- 1 x Flat Head Screwdriver

Warranty

Covered by Metcalfe 2-year warranty (1st year parts and labour, 2nd year parts only) and full after sales service

Optional Accessories

| Item |
|------------------------------------|
| Tray Extension Device |
| Stainless Steel Guard |
| Product Hold Bar for Gravity Plate |
| Serrated Blade |

| Item |
|--|
| Special Stainless-Steel Handgrip |
| Teflon Coated Parts (Blade Cover, Gauge Plate, Blade) |
| Special Arm (Protected) |
| Painting Customisation |

| Item |
|-------------------------------|
| Stainless Steel Knife Remover |
| Aluminium Knobs |
| Plastic Cover – Small |

Drawing

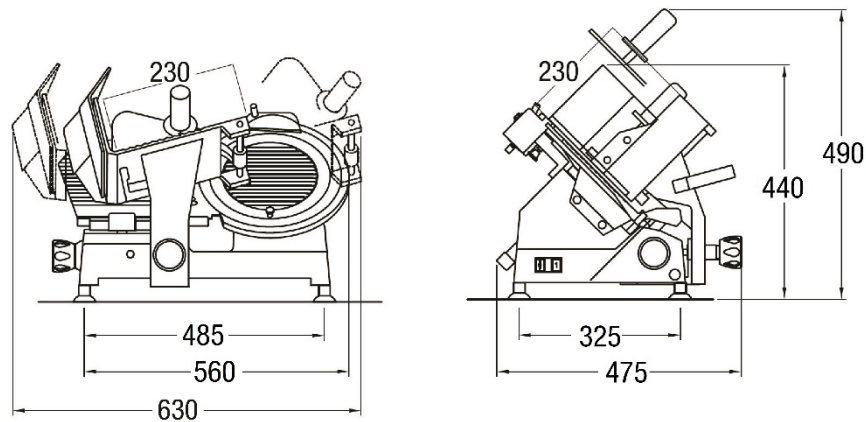

Specifications

| Model | Blade (mm) / (Inch) | Phase (Ø) | Motor (Volt) | Frequency (Hz) | AMP (A) | Power (kW) |
|---------|---------------------|-----------|--------------|----------------|---------|------------|
| NS250HD | 250 / 10 | 1 | 220 | 50 | 1.2 | 0.18 |

Capacity

| Model | Cutting Capacity (mm) | | Carriage Movement (mm) | Max Thickness (mm) |
|---------|-----------------------|-------------|------------------------|--------------------|
| NS250HD | ● 175 | □ 175 x 220 | 270 | 12 |

Dimensions | Shipping Information

| Model | Overall Dimensions (D x W x H) | Net Weight (Kg) | Packed Dimensions (D x W x H) | Packed Weight (Kg) | Volume (m3) |
|---------|--------------------------------|-----------------|-------------------------------|--------------------|-------------|
| NS250HD | 475 x 630 x 490 | 19.0 | 560 x 660 x 620 | 22.0 | 0.229 |

We reserve the right to alter the specification and technical details for this item at anytime without prior notice.

©Metcalfe Catering Equipment Ltd

NS250HD Rev: 1 03/2019

| | | |
|---|--|---|
| <p>Metcalfe Catering Equipment Ltd Haygarth Park Blaenau Ffestiniog Gwynedd LL41 3PF Tel: 01766 830 456 Fax: 01766 831 170 E-mail: sales@metcalfecatering.com</p> | | <p>View our current catalogue visit: www.metcalfecatering.com/brochure Or scan the QR code</p>  |
|---|--|---|